

## **RLC RING TORSION LOAD CELL (28/60t)**



### **DESCRIPTION:**

The RLC is a low profile, high performance stainless steel ring torsion type load cell.

This product is suitable for high capacity platforms as well as process weighing applications.

The fully welded construction and glass-to-metal cable-entry ensure that this product can be used successfully in harsh environments found in the food, chemical and allied process industries.

This product meets the stringent Weights and Measures requirements throughout Europe.

### **FEATURES:**

- Low profile, stainless steel construction
- Hermetically sealed, IP66 and IP68
- Meets OIML R-60, **3000d**
- High bridge impedance
- ATEX certified versions are available for use in potentially explosive atmospheres
- Outputs are matched to ensure easy and accurate parallel connection of multiple load cells
- Multi-interval and multiple range versions are available
- **CAPACITIES: 28 and 60t**

# RLC: SPECIFICATIONS

Standard Capacities (=E <sub>max</sub> )	t	28, 60		
Accuracy Class According to OIML R-60			C2	C3
Max. Number of Verification Intervals (n <sub>ic</sub> )			2000	3000
Minimum Verification Interval	V <sub>min</sub>		E <sub>max</sub> /7500	E <sub>max</sub> /10000
Minimum Verification Interval, <b>Version MR</b>	V <sub>min</sub>		E <sub>max</sub> /15000	E <sub>max</sub> /15000
Accuracy According to Type Designation		CC	C2	C3
Combined Error	%S	≤ ± 0.0500	≤ ± 0.0230	≤ ± 0.0200
Non-repeatability	%s	≤ ± 0.0200	≤ ± 0.0100	≤ ± 0.0100
Hysteresis	%S		≤ ± 0.0250	≤ ± 0.0167
Minimum Dead Load Output Return <sup>1</sup>	%S	≤ ± 0.0500	≤ ± 0.0250	≤ ± 0.0167
Creep Error (30 Minutes) <sup>1</sup>	%S	≤ ± 0.0600	≤ ± 0.0245	≤ ± 0.0245
Creep Error (20-30 Minutes) <sup>1</sup>	%S	≤ ± 0.0200	≤ ± 0.0053	≤ ± 0.0053
Temp. Effect on Min. Dead Load Output	%S/5°C	≤ ± 0.0250	≤ ± 0.0035	≤ ± 0.0035
Temperature Effect on Sensitivity	%S/5°C	≤ ± 0.0250	≤ ± 0.0060	≤ ± 0.0040
Minimum Deadload	%E <sub>max</sub>		0	
Maximum Safe Overload	%E <sub>max</sub>		150	
Ultimate Overload	%E <sub>max</sub>		300	
Maximum Safe Sideload	%E <sub>max</sub>		50	
Deflection at E <sub>max</sub>	mm		0.17...0.20	
Excitation Voltage	V		...30	
Recommended Excitation Voltage	V		15	
Rated Output (=S)	mV/V		2	
Output Accuracy for multiple LC systems	%		± 0.1	
Zero Balance	%S		≤ ± 1.0	
Input Resistance	Ω		1075 ± 100 for 28t and 1350 ± 100 for 60t	
Output Resistance	Ω		930 ± 0.5 for 28t and 1175 ± 0.5 for 60t	
Insulation Resistance	MΩ		≥ 20	
Compensated Temperature Range	°C		-10...+40	
Operating Temperature Range	°C		-30...+70	
Storage Temperature Range	°C		-50...+80	
Element Material (DIN)			Stainless Steel 1.4542	
Sealing (DIN 40.050 / EN 60.529)			IP66 and IP68	
ATEX opt. for potent. explosive atmospheres <sup>2</sup>			II2G EEx ib IIC T4/T6 or II1D T70°C or II3G EEx nA II T4/T6 or II3D T70°C	

1 Applies for the temperature range -10 to +40 °C

2 Applies for the temperature range -20 to +40 °C

Accuracy classes C2 and C3 are in agreement with the OIML recommendation R-60.

The correct mounting of the load cells is essential to ensure optimum performance. Further information is available on request.

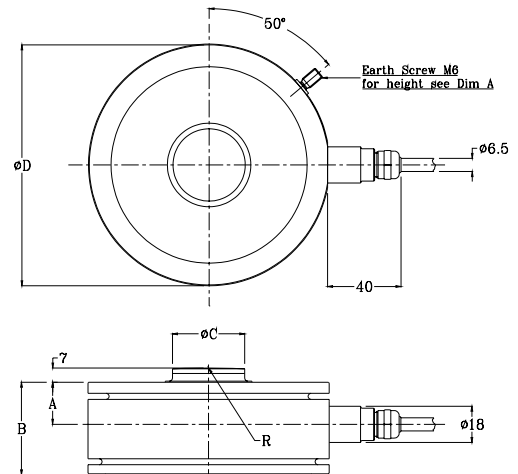

### Cable specifications:

Cable length 10m for 28t version and 15m for 60t version.

Excitation + Pink  
 Excitation - Grey  
 Output + Brown  
 Output - White  
 Shield Transparent

Cable screen is not connected to load cell body. Performance may be affected if load cell cables are shortened.

Capacity (t)	28	60
A	21	28
B	46	62
C	35.9	47.9
D	120	140
R	400	600

### Attention:

Dimensions: mm.  
 All dimension tolerances according to ISO 2768m, unless otherwise specified.

All specifications subject to change without notice